

# INSTALLATION INSTRUCTIONS

## FOR REPLACEMENT COILS USED IN AIR HANDLERS

(-)CH: featuring Industry-Standard R-410A  Refrigerant



**RECOGNIZE THIS SYMBOL AS AN INDICATION OF IMPORTANT SAFETY INFORMATION!**

### **⚠ WARNING**

These instructions are intended as an aid to qualified licensed service personnel for proper installation, adjustment and operation of this unit. Read these instructions thoroughly before attempting installation or operation. Failure to follow these instructions may result in improper installation, adjustment, service or maintenance possibly resulting in fire, electrical shock, property damage, personal injury or death.



**ISO 9001:2008**

Certificate Number: 30164

**DO NOT DESTROY THIS MANUAL**

**PLEASE READ CAREFULLY AND KEEP IN A SAFE PLACE FOR FUTURE REFERENCE BY A SERVICEMAN**



**FIGURE 1**  
MODEL NUMBER EXPLANATION

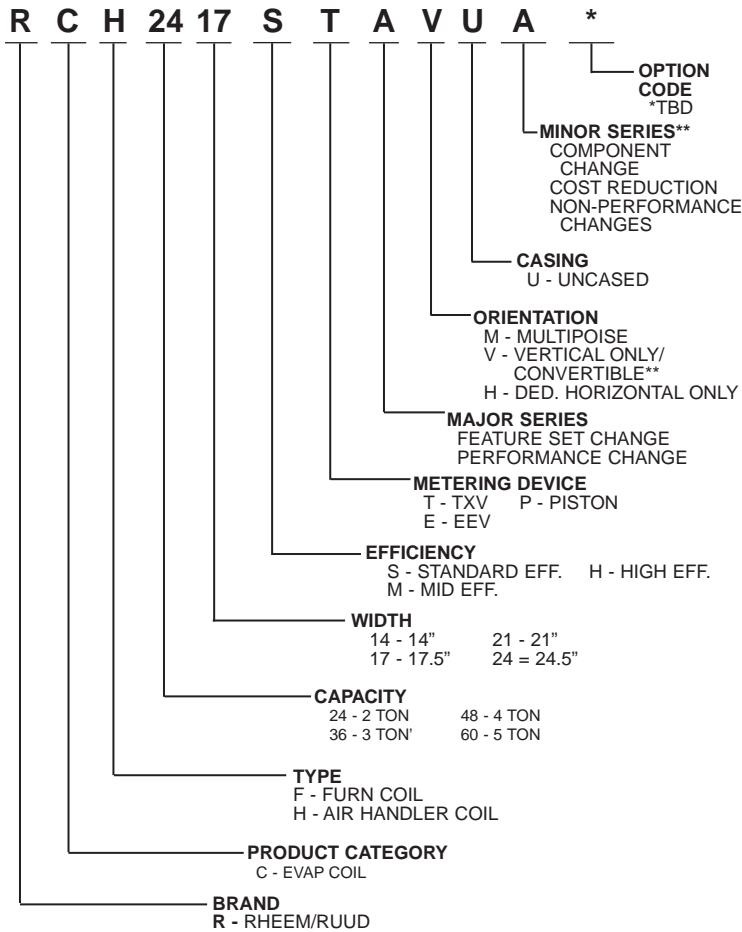

"All replacement coils for HM and AU air handler applications will be HU."  
\*\*Convertible to horizontal using parts from original coil or using RXHH horizontal adapter kit.

## GENERAL

(-)CH is a replacement only uncased coil. (-)CH-replacement coils are used only in (-)HKL, (-)HLL, (-)HLP, (-)HML, (-)HPL, (-)HPN and (-)HSL R410A air handlers.

For horizontal applications, a horizontal drip shield and water management parts (see Figure 1) must be installed to catch excess condensate drainage.

**FIGURE 1**

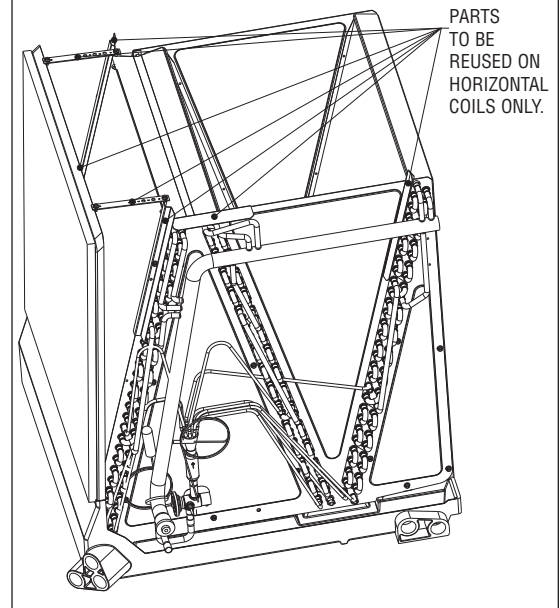

**TABLE 1**  
R-410A UNCASSED COILS: (-)CSL- ACCESSORY INFORMATION

Replacement R-410A Uncased Coil	Original Coil	Horizontal Adapter Kit Model Number
RCH2417STAVUA	RCSL-HU2417CU	RXHH-A02
RCH2421MTAVUA	RCSL-HU2621CU	RXHH-A03
RCH3617STAVUA	RCSL-HU3617CU	RXHH-A03
RCH3621STAVUA	RCSL-HU3621CU	RXHH-A03
RCH3621MTAVUA	RCSL-HU3821CU	RXHH-A04
RCH3624MTAVUA	RCSL-HU3824CU	RXHH-A04
RCH4821STAVUA	RCSL-HU4821CU	RXHH-A04
RCH4824STAVUA	RCSL-HU4824CU	RXHH-A04
RCH6024STAVUA	RCSL-HU6024CU	RXHH-A05
RCH2421HTAVUA	RCSN-HU2421CU	RXHH-A03
RCH3624HTAVUA	RCSN-HU3624CU	RXHH-A05
RCH4824HTAVUA	RCSN-HU4824CU	RXHH-A05
RCH6024HTAVUA	RCSN-HU6024CU	RXHH-A05
RCH2417SPAVUA	RCSP-HU2417CU	RXHH-A02
RCH3617SPAVUA	RCSP-HU3617CU	RXHH-A03
RCH4821SPAVUA	RCSP-HU4821CU	RXHH-A04